

5G-Crosshaul Architecture Overview

5GPPP Workshop on 5G RAN Design, Air Interface Design and Integration
Valencia –January 2016

Dr. Xavier Costa Perez

5G-Crosshaul Technical Manager

NEC Laboratories Europe

Heidelberg. Germany

The 5G Integrated Fronthaul/Backhaul Transport Network

5G X Crosshaul

Formerly: Xhaul project

Website: www.5g-crosshaul.eu

Project overview: 'Xhaul: Toward an integrated fronthaul backhaul architecture in 5G networks', IEEE Wireless Communications Magazine, Oct 2015

Orchestrating a brighter world

NEC

5G-Crosshaul Overview

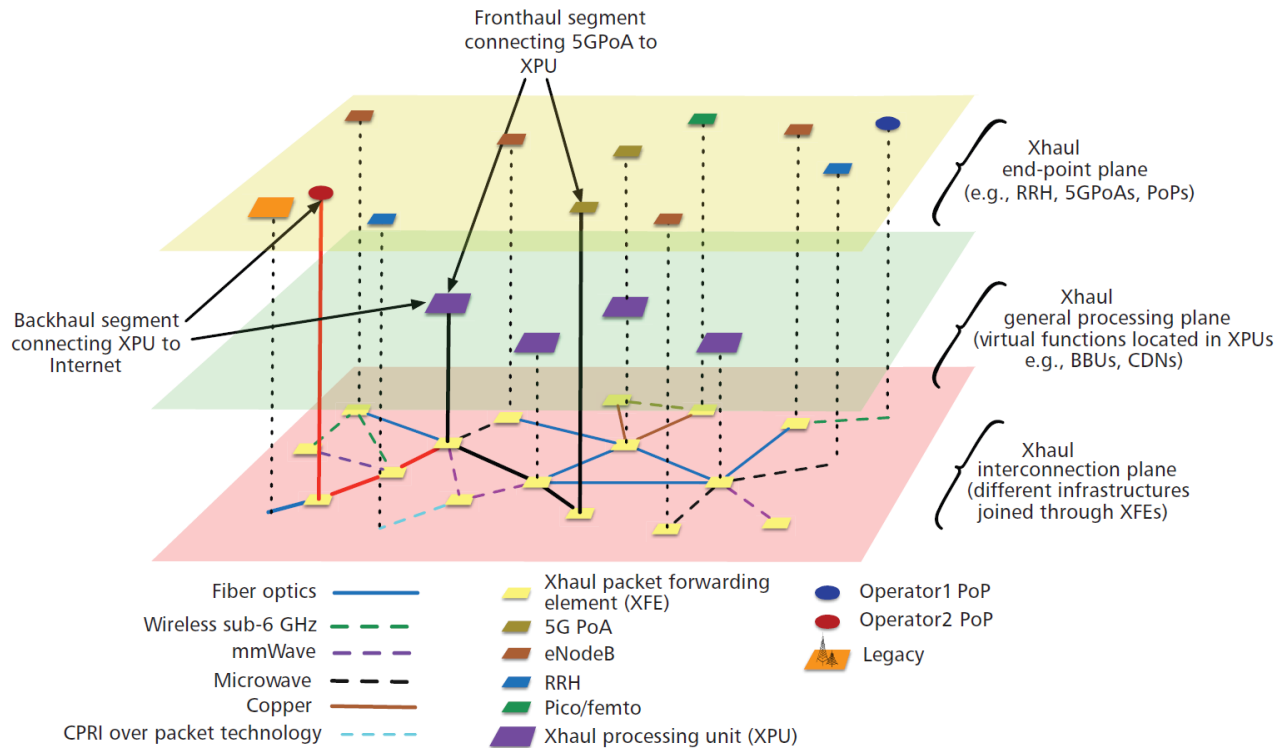

Project Consortium

Operators

Orange, Telefonica, Telecom Italia

Vendors

ATOS, Ericsson, Interdigital, NEC, Nokia

Broadcaster/ Tech. Provider

Visiona, Telnet

SMEs

Eblink, Nextworks, CND,

R&D Centers

Create-net, CTTC, Fraunhofer HHI, ITRI

Universities

Univ. Carlos III, Univ. Lund, Pol.Torino

PM - Arturo Azcorra (UC3M)

TM - Xavier Costa (NEC)

R&D Areas

- Unified control plane for fronthaul/backhaul SDN/NFV-based (XCI)
- Unified data plane for fronthaul/backhaul technologies (XCF, XFE)
- 5G-enabling transm. techs, e.g., mmWave, uWave, optical and copper
- UCs: Dense Urban Society, Multi-Tenancy, Media Distr, MEC, Vehicular
- 5G-Crosshaul demonstration testbeds in Berlin, Madrid, Barcelona, Taiwan

5G-Crosshaul - Main Building Blocks

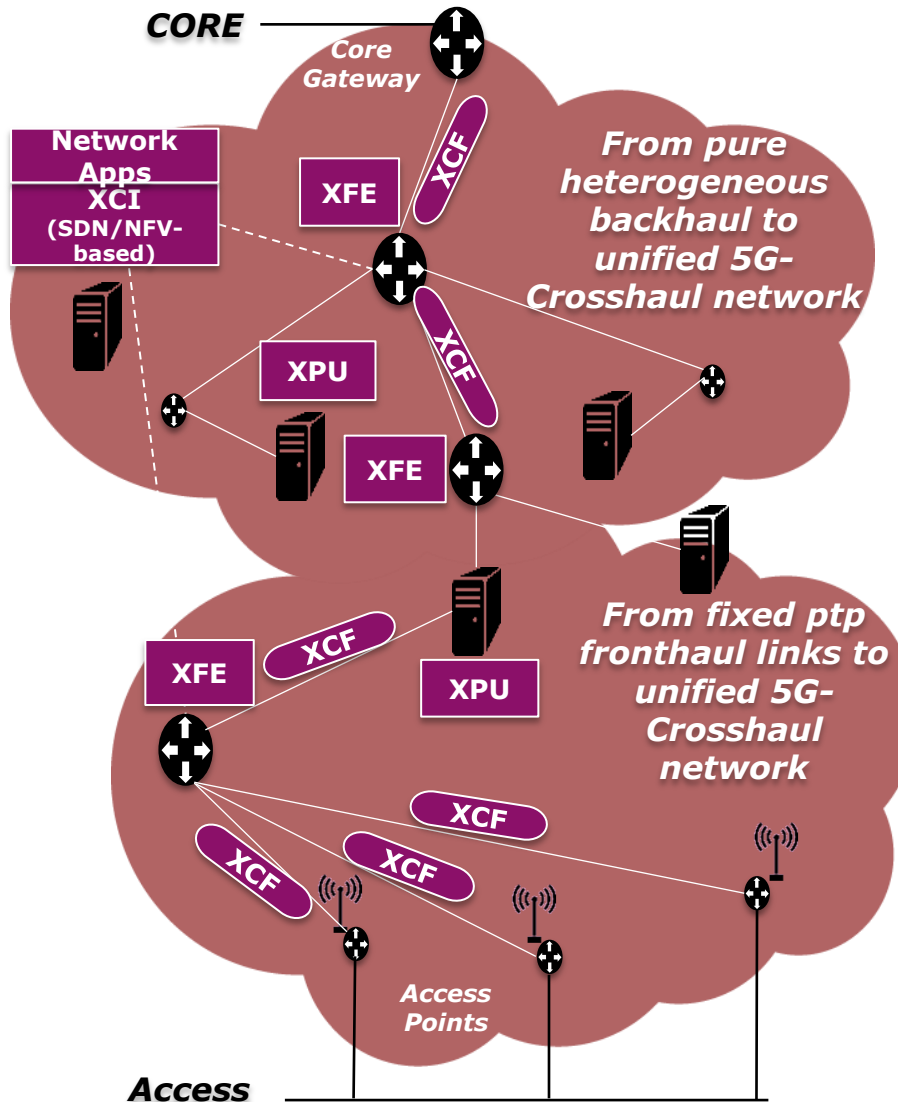

A holistic approach for converged Fronthaul and Backhaul under common SDN/NFV-based control, capable of supporting new 5G RAN architectures (vRAN) and performance requirements

Main building blocks

- **XCF – Common Frame** capable of transporting the mixture of various Fronthaul and backhaul traffic
- **XFE – Forwarding Element** for forwarding the Crosshaul traffic in the XCF format under the XCI control
- **XPU – Processing Unit** for executing virtualized network functions and/or centralized access protocol functions (vRAN)
- **XCI – Control Infrastructure** that is SDN-based and NFV-enabled for executing the orchestrator's resource allocation decisions
- **Novel network apps** on top to achieve certain KPIs or services

5G-Crosshaul Architecture - Overall view

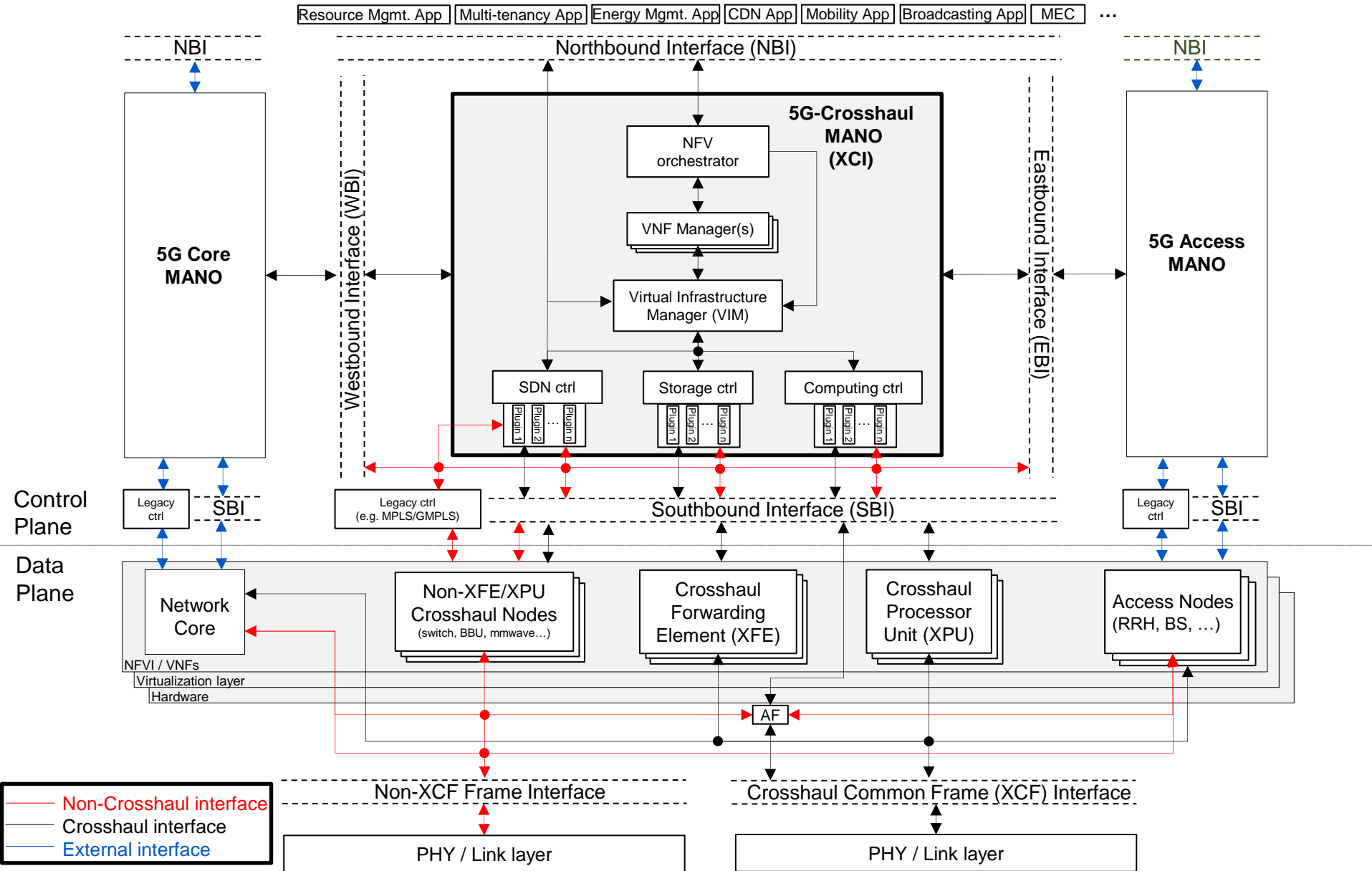

5G-Crosshaul Architecture - Overall view

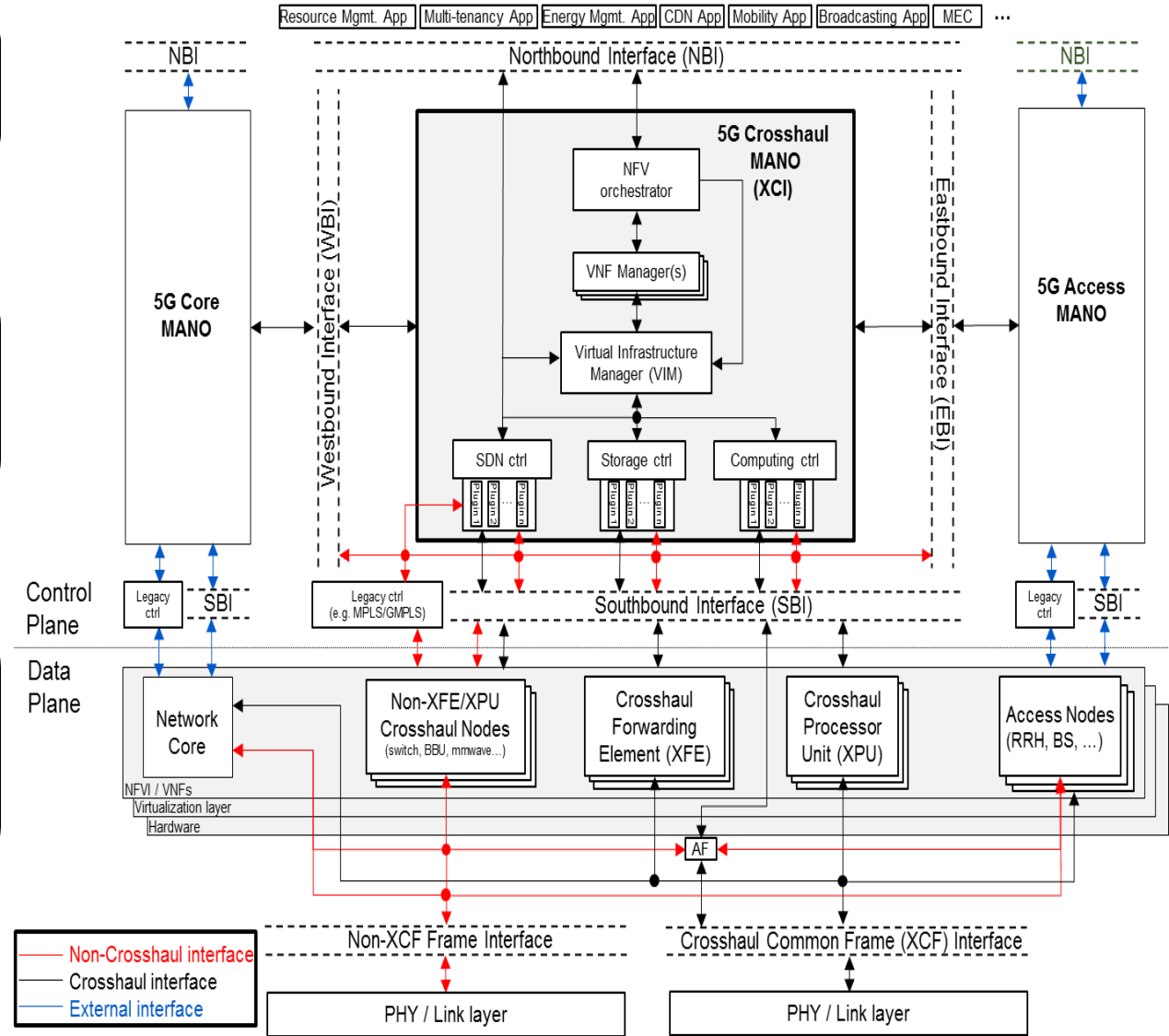
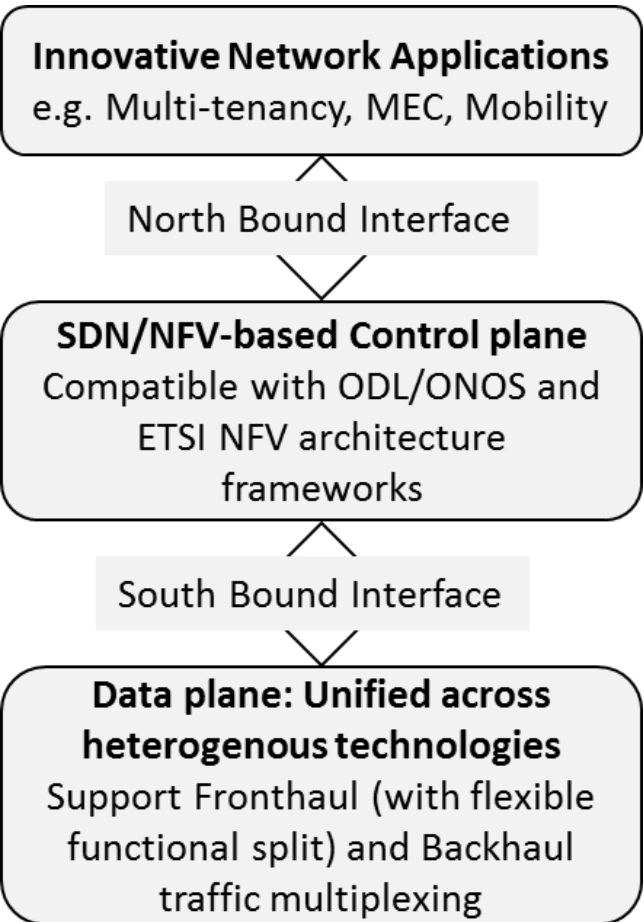

Thank you for your attention

5G X Crosshaul

